



**MIZARSTVO**  **Jezeršek**  
Izdelava stopnic







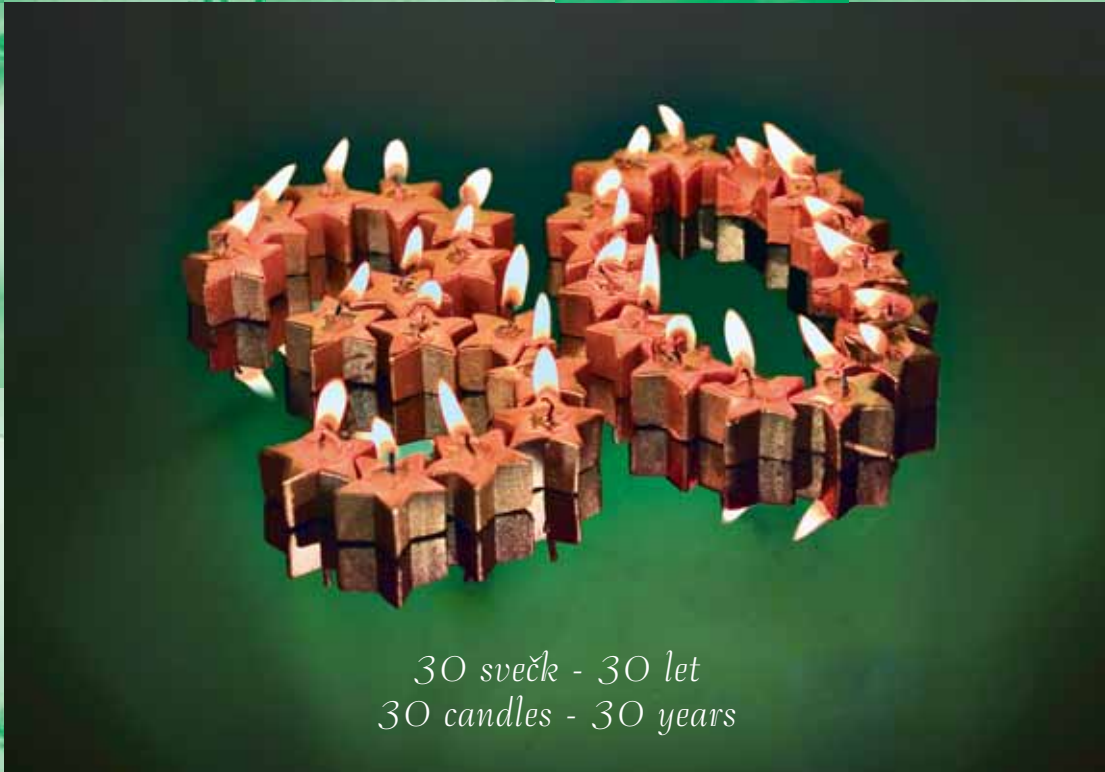



Sredi prejšnjega tisočletja je italijanski kipar Michelangelo na vprašanje, kako je lahko izklesal tako impresivno skulpturo, odvrnil: »V tem kosu kamna je bila vedno figura konja, jaz sem le odstranil tisto, kar je bilo odveč.«

Tudi v poljanskih hribih posekana drevesa imajo v sebi od nekdaj skrite stopnice. V mizarstvu Jezeršek le odstranijo les, ki je odveč. V njihovih rokah se domača surovina, poljanski les, spreminja v izdelek, ki ga uporabljamo vsak dan. V leseno skulpturo, v unikaten izdelek.

V stopnice.

Ljubezen je temelj srečnega življenja.

Ljubezen do družine in do ljudi, ki nas obdajajo, ter ljubezen do dela, ki ga opravljamo.

Kadar ljubiš svoje delo, kadar ga opravljaš z resničnim navdušenjem, takrat lahko postaneš v svojem poklicu mojster, ki zmore mojstrske presežke.

Zato se je pred tridesetimi lahko pričela zgodba o Mizarstvu Jezeršek in zato se lahko nadaljuje tudi danes ...

---

In the middle of the previous millenium the Italian sculptor Michelangelo answered the question how he created such an impressive sculpture with the following words "In this piece of rock there has always been a horse sculpture, I have just removed whatever there was too much of."

The trees cut down in the Poljane Valley have always hidden stairs inside them. At the carpentry Jezeršek only that is removed what there is too much of. In their hands the local material, the wood of Poljane, evolves into a product for everyday use.

Into a wooden sculpture, a unique product.

Into stairs.

Love is the foundation of a happy life.

Love for one's family and people, who surround us as well as love for work that we do.

When you love your work, when you complete it filled with enthusiasm, then you can become a master of your trade, a master who is able to achieve an incredible surplus.

That is why the story of Carpentry Jezeršek started thirty years ago and that is why it can continue today...

---

Mitten des vorigen Jahrhunderts gab der italienische Bildhauer Michelangelo auf die Frage, wie es ihm überhaupt gelinge eine solche eindrucksvolle Skulptur herauszuhauen, folgende Antwort: „In diesem Stein steckte schon immer eine Figur von einem Pferd, ich habe nur das Überflüssige entfernt.“

Auch in den gefälltten Bäumen aus Poljaner Bergen werden schon seit je die Treppenstufen verborgen.

In der Tischlerei Jezeršek wird ebenfalls nur das Überflüssige Holz entfernt. Der einheimische Rohstoff, der Poljaner Holz, wird in deren Händen in ein Produkt verarbeitet, das man jeden Tag gebrauchen kann.

In eine Holzskulptur, in ein Unikatprodukt.

In eine Treppenstufe.

Die Liebe ist die Grundlage für ein glückliches Leben.

Die Liebe zu Familie und zu Mitmenschen, die uns umgeben und die Liebe zu Arbeit, die wir ausüben.

Wenn man die Arbeit liebt und sie mit großer Begeisterung ausübt, dann wird man zum Meister seines Faches, zum Fachmann, der alle meisterhafte Überschüsse erzielt.

Aus diesem Grund begann vor dreißig Jahren die Geschichte von Tischlerei Jezeršek, und sie geht noch heute weiter ...

---

В середине прошлого тысячелетия итальянский скульптор Микеланджело на вопрос, как он умел вырезать такую импрессионную статую, ответил: «В этом куске камня всегда находилась фигура лошади, я только отсек от камня все лишнее.»

Также в деревьях, срубленных в горах в Полянской Долине, уже давно скрываются ступеньки. На столярном предприятии Езершек только устраняют лишние куски дерева. Родное сырье, дерево из Полянской Долины, таким образом превращается в готовое изделие, употребляемое каждый день.

В деревянную скульптуру, в уникальное изделие.

В ступеньки.

Любовь является основой счастливой жизни.

Любовь к семье, к окружающим нас людям, и любовь к выполняемой нами работе.

Если вы любите свою работу, если выполняете ее с большим удовольствием, тогда вы в своей профессии можете стать мастером, способным к большим достижениям.

Таким образом тридцать лет назад началась история о Столярничестве Езершек, и таким образом она может продолжаться в настоящее время ...





*Obrtnik leta 2004 - Best craftsman of 2004*





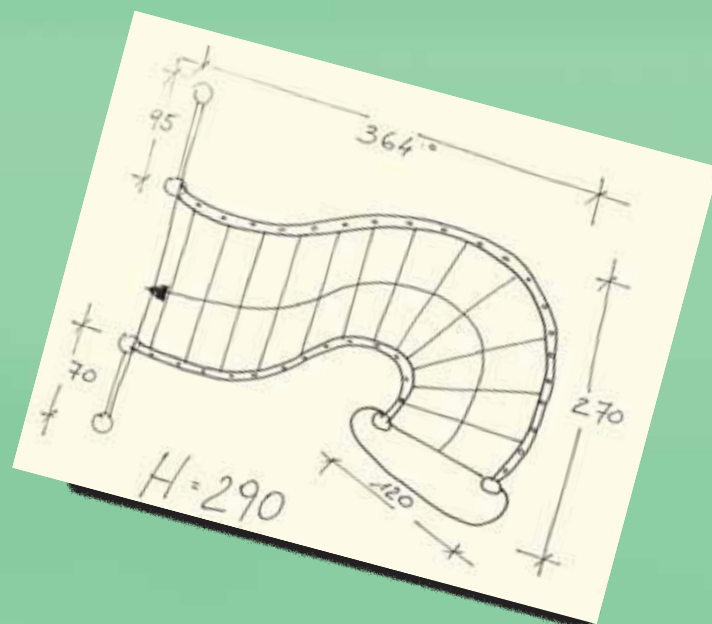







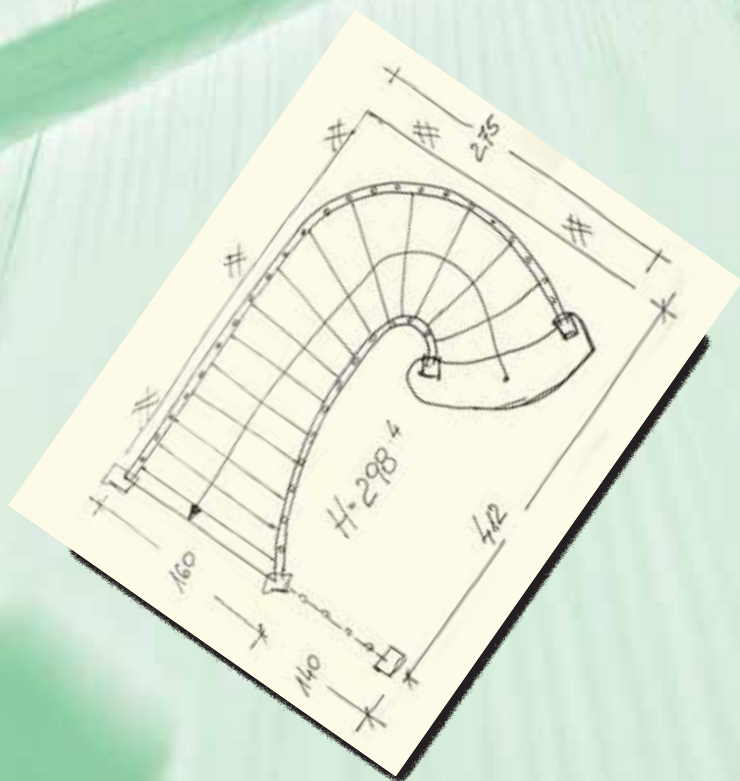







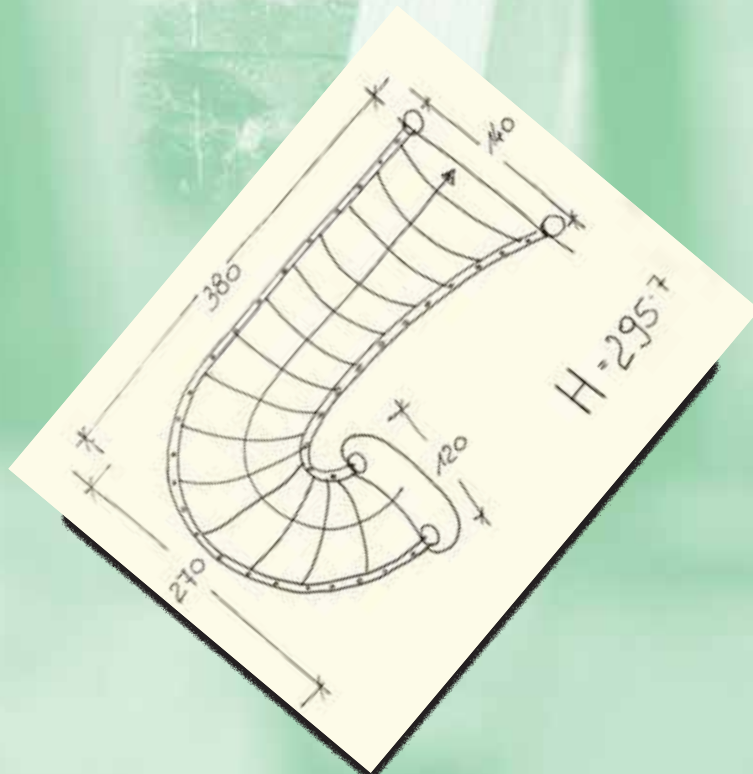







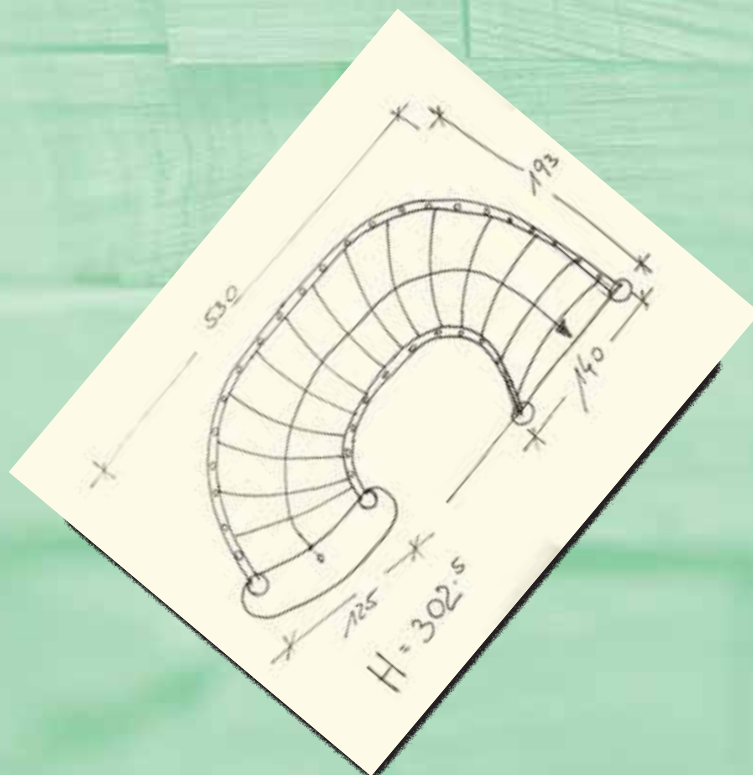







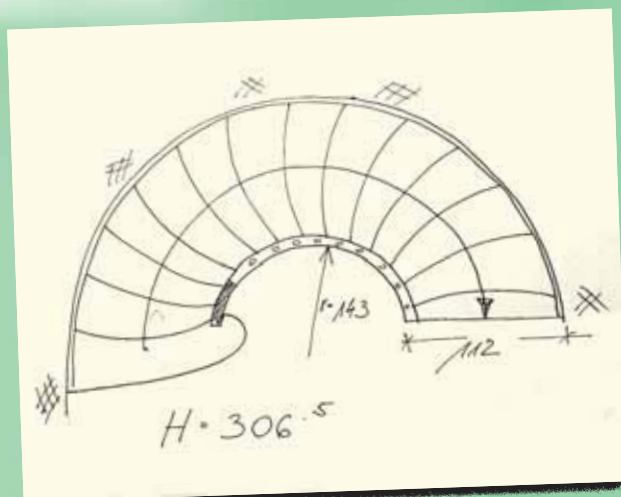







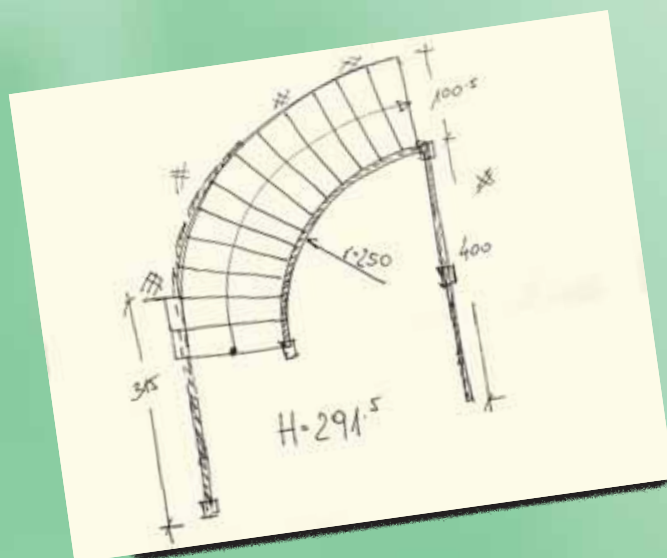















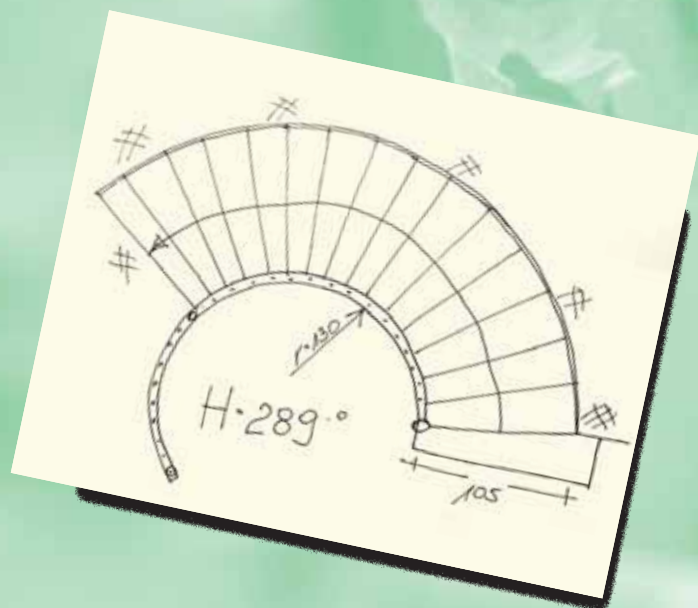







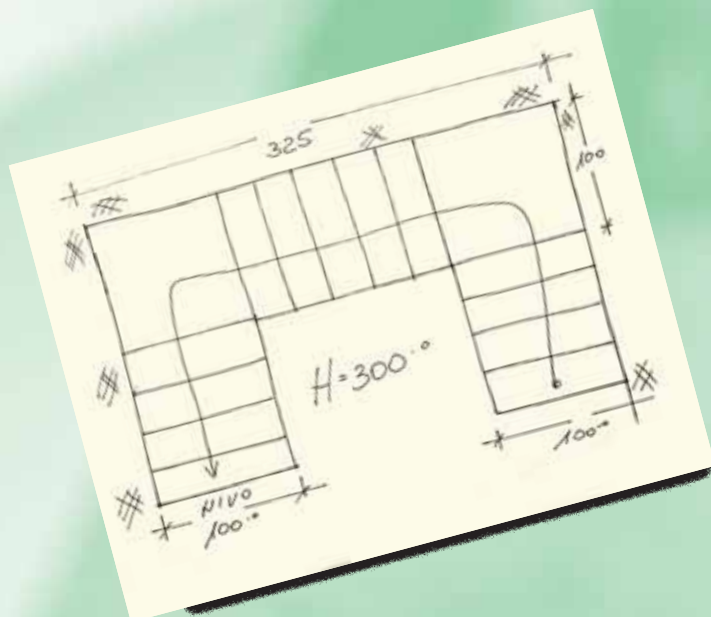





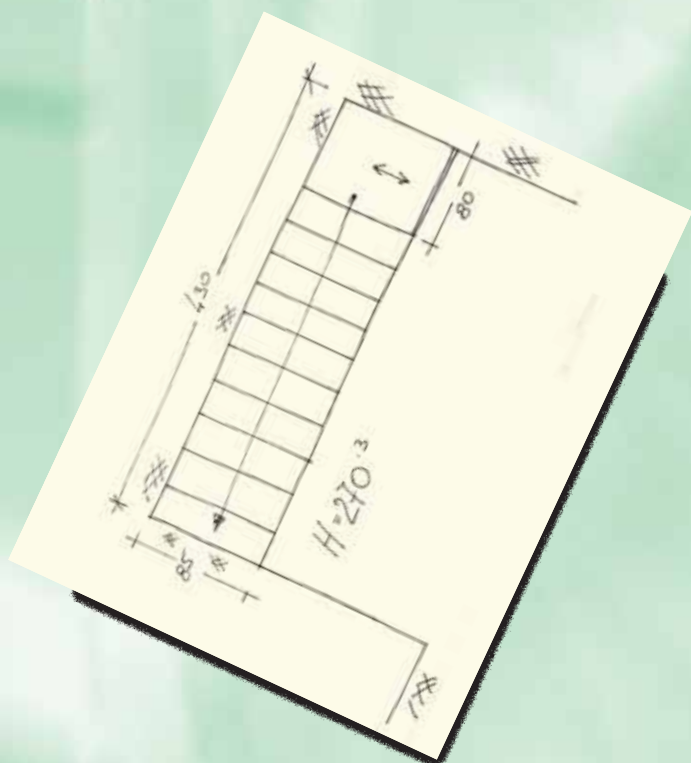





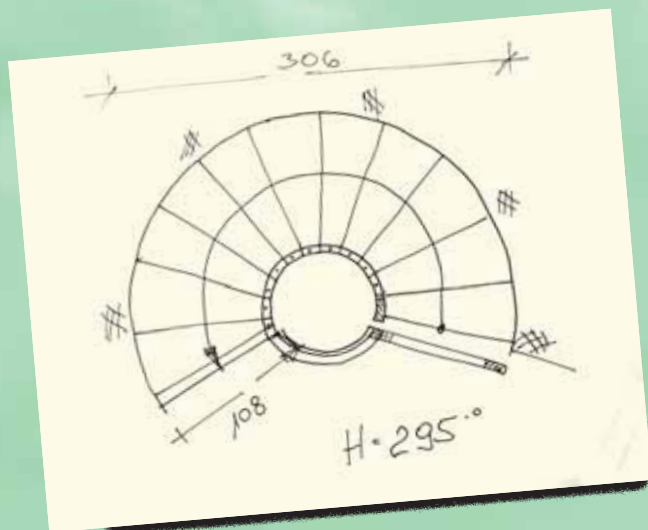
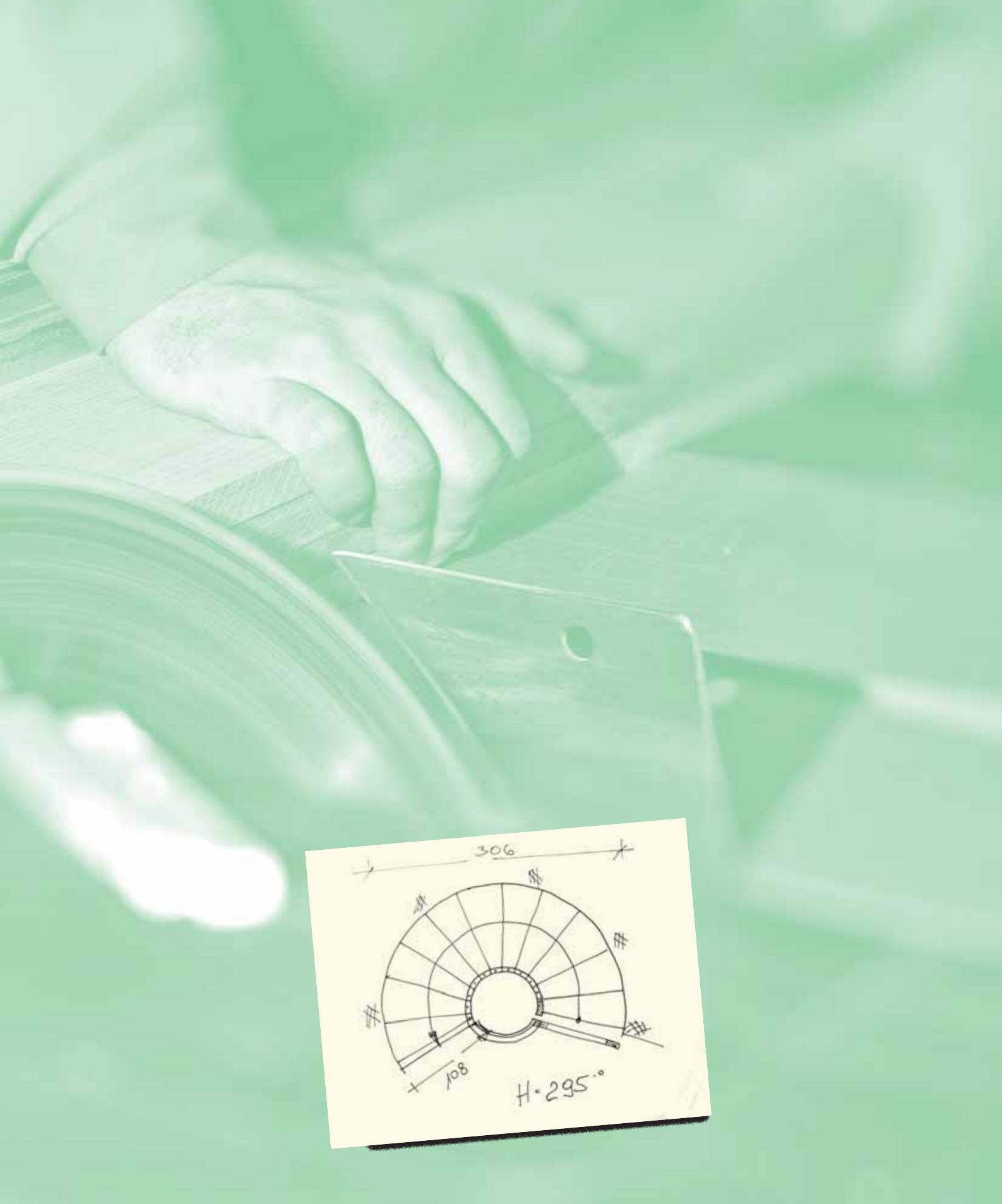





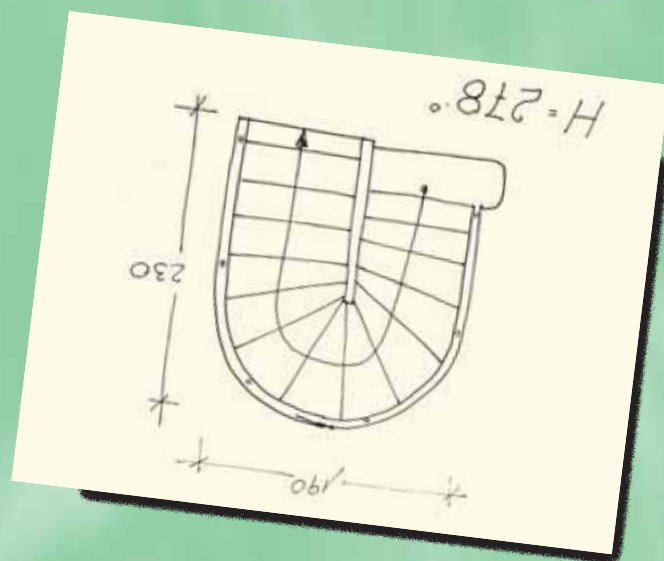





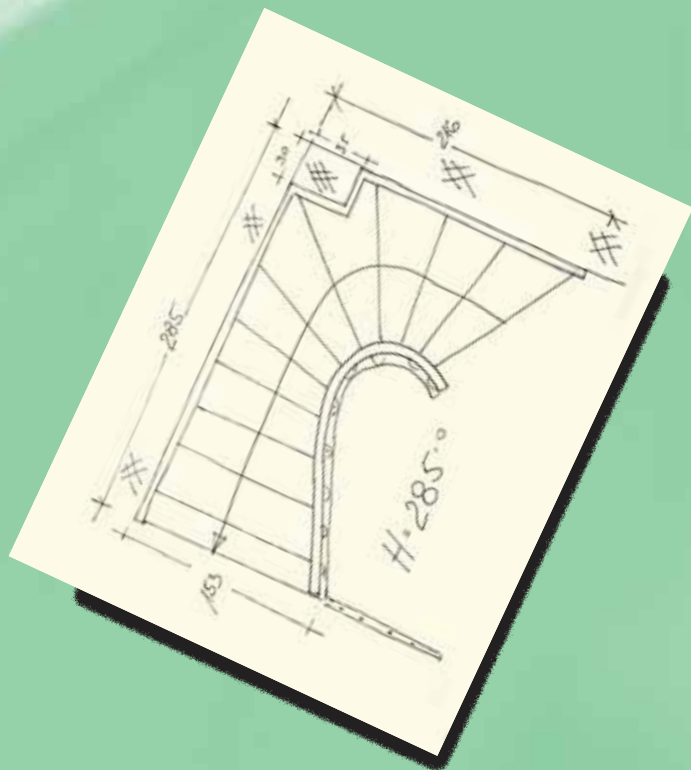





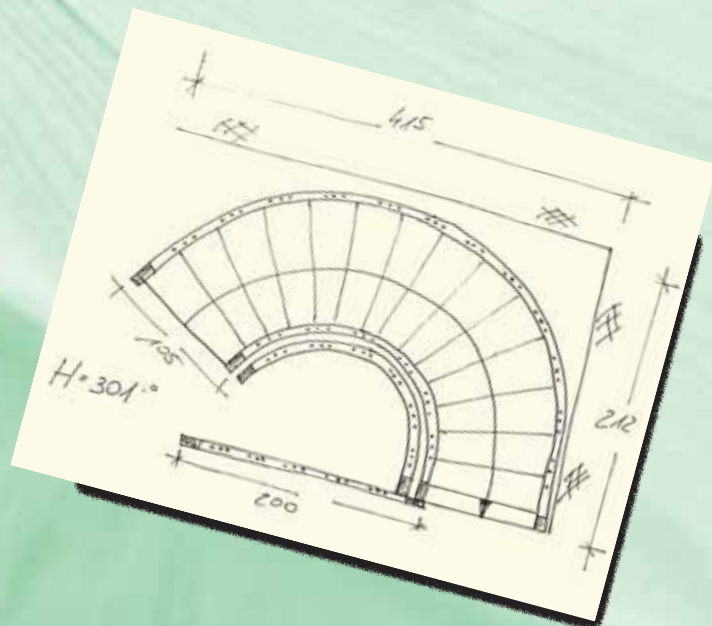





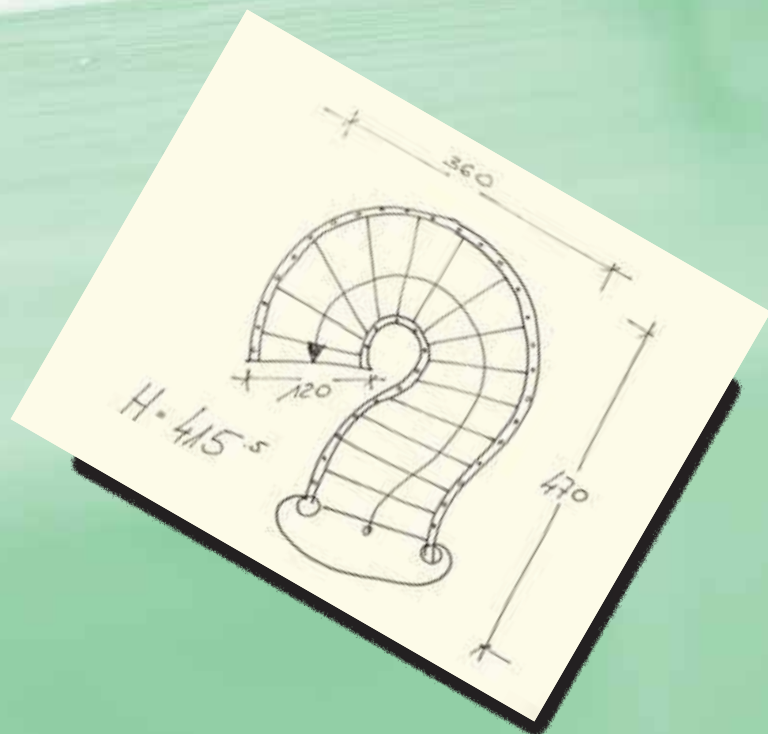





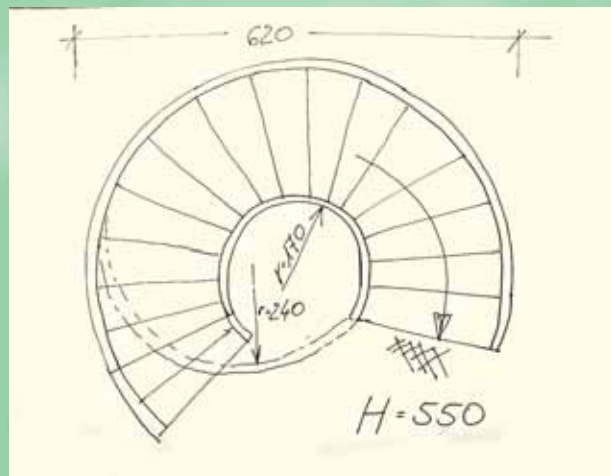
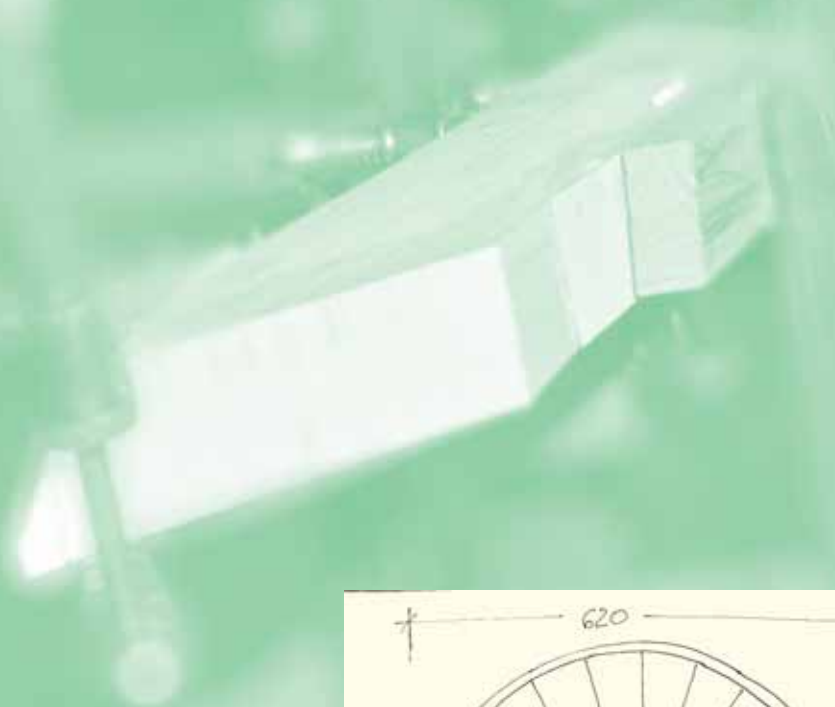





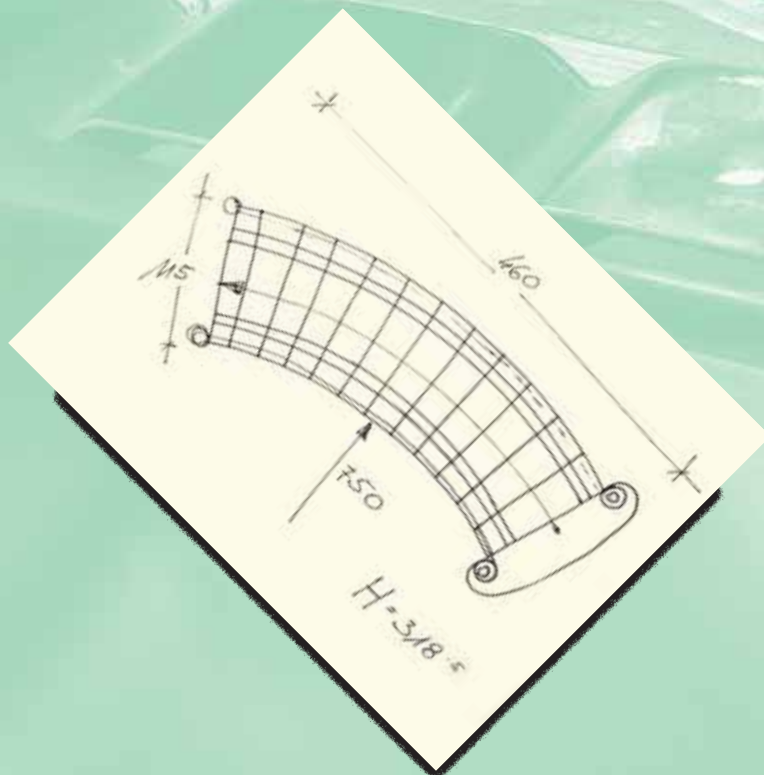





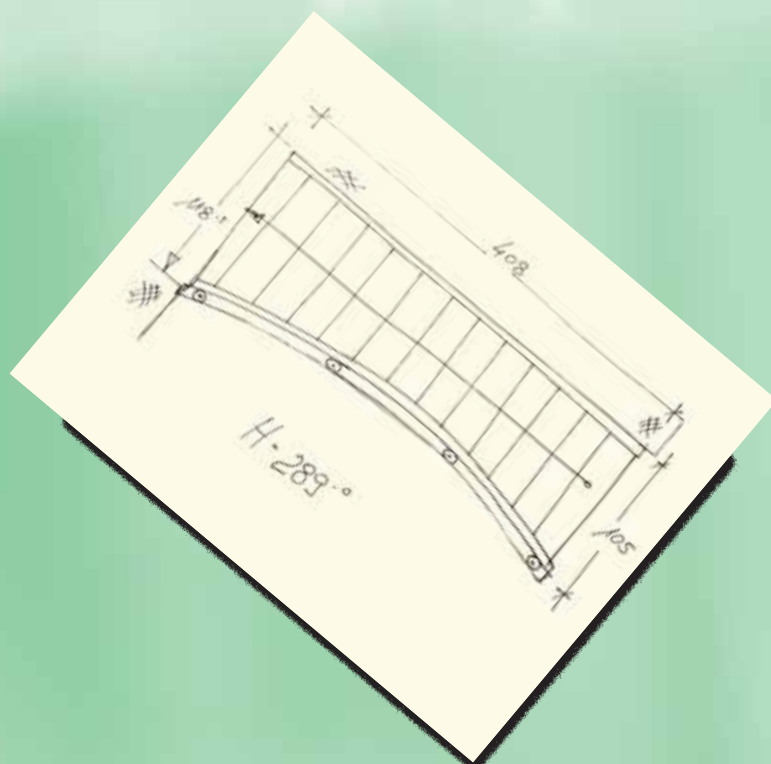



Nosilni stebrički - Newels - Die Geländertragepfosten



Ograjni stebrički - Balusters - Die Geländerstäbe









# MIZARSTVO Jezeršek

Izdelava stopnic

Mizarstvo Jezeršek, Hotavlje 7b, 4224 Gorenja vas, Slovenija  
Tel.: +386 (0)4 51 81 548, Fax: +386 (0)4 51 80 099,  
E-mail: [info@stopnice-jezersek.si](mailto:info@stopnice-jezersek.si), Internet: [www.stopnice-jezersek.si](http://www.stopnice-jezersek.si)